

# **RHEA II: Remote Harvester Earth Analogue a.k.a. "Ros\_E"**

RASC-AL RoboOps 2012 Final Report

University of Maryland  
Department of Aerospace Engineering

Project Advisor: Dr. David L. Akin  
Associate Professor of Aerospace Engineering

Team Members: Luke Alberto  
Sahil Ambani  
Henry Elder  
Joshua Fogel  
Duarte Ho  
Brad Hood  
Sam Lewis  
Sean Li  
Jose Mora  
Jamil Shehadeh  
Walter Taraila  
Mike Tsu  
Terry Van Wormer  
Daniel Villabolas

## **Introduction**

The University of Maryland is proud to present this year's entry to the 2012 RASC-AL RoboOps Competition with the Remote Harvester Earth Analogue (RHEA) -II, also nicknamed Ros\_E. Ros\_E is an updated version of last year's entry RHEA-I to the RoboOps competition which placed 3rd overall. This year, the team has been working hard to build on last year's successes and improve on weaknesses. Ros\_E's chassis and drive system have remained the same since last year to handle the various terrains in the JSC Rockyard. The end effector has been changed to enhance Ros\_E's ability to capture target rocks. The biggest change from last year however was on the electronics and software side. The onboard electronics have been revamped almost completely so that controlling the arm and the vehicle have been improved. 3 different cameras are also being used and the improved software allows the operator to freely switch between video feeds, which proved to be an issue in last year's design. All this together will improve Ros\_E's performance overall to target and acquire rocks for this year's competition.

## **1 Mechanical Structure**

### **1.1 Chassis and Drive System**

A review of the 2011 competition run and from interviews with previous team members allowed the 2012 team to determine where major improvements were needed. The chassis was proven both reliable and effective during the 2011 run on the various terrains of the competition. The RHEA chassis was designed as a rectangular platform using 6061 Aluminum, thin walled, square beams. The thin-walled square beams provide the rigidity needed to support the components while keeping the design of the chassis light. The rectangular construction allowed for simple and stable mounting of all the components of the rover using a combination of bolts and nuts for some parts and rivets for more permanent construction. A crucial component of the chassis was the placement of its battery under the plane of the platform which lowers the center of gravity and reduces the risk of rolling during operation.

Ros\_E has four rigid aluminum beams that raise the body of the chassis off the ground by about 10 centimeters. This allows for clearance over gravel and small rocks as the rover traverses the various terrains within the competition grounds. These rigid beams connect the gear motors to the chassis and allow for a four wheel drive skid steering design to drive the rover. Last year's group reported much success with this design and improvements in drivability and software described later make it even more effective for the team member controlling the rover. The custom milled polyurethane tires and tread design were also reused from last year. The high traction, rectangular grouser pattern was able to provide adequate drawbar pull with minimal lateral resistance during skid steering. These tires were fitted to lightweight aluminum wheels which gave a final diameter of 20 cm, then connected directly to the gear motor output shaft to minimize play. With the wheels on Ros\_E is able to routinely scale obstacles around 20 cm in height.

Next year's class will focus on chassis redesign to eliminate and change the current aluminum body to a composite structure. This redesign should also include a rocker mechanism or other suspension system that will help distribute weight evenly over the wheels when driving across the uneven terrain.

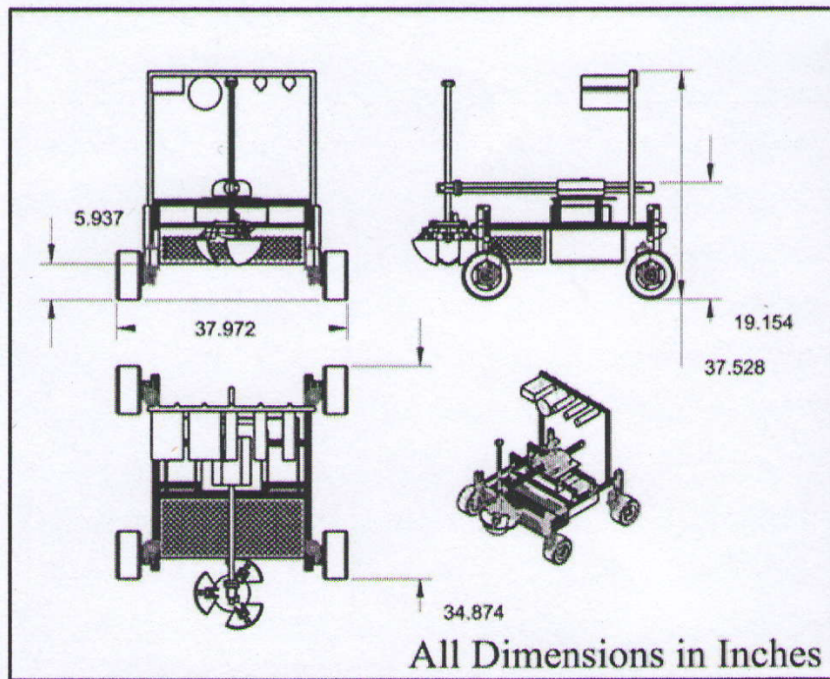

## 1.2 Arm

The RHEA-II sampling arm is a four degree of freedom revolute manipulator with a redesigned rock-gripping end effector. Each degree of freedom is controlled by high-torque servos, which is generally mounted proximal to the actuated joint for low tip mass, and is articulated via pushrods. The basic kinematics is roll-pitch-pitch, which provides a spherical workspace under joint-by-joint control by the operator. A stepper motor drives the opening and closing of the end-effector via a miniature lead screw. The new configuration of the end-effector was chosen because it proved to be the most reliable, effective and simple solution to meet our requirements.

It was decided not to redesign an entirely new robotic arm because the RHEA-I arm hardware was still effective and functional, despite minor end effector structural concerns and significant software flaws. It was agreed upon to maintain the RHEA-I robotic arm and instead redesign the end effector and focus on the software control of the capture kinematics.

The new end-effector has only two main gripping “hands” machined from stainless steel plates at the Space Systems Laboratory. As opposed to the Rhea-I claw which captures rocks with a four-finger pinch approach, the RHEA-II end effector fully encloses the sample with two curved metal hands. The end-effector contact surface area is covered with a high friction material to increase the friction with the sample to account for partial rock capture. The stepper motor actuates the hands, allowing them to open to an excess of a 10 cm gape to confidently capture even the largest rocks in the JSC Rockyard. It was proven through testing that reducing the number of fingers from four to two while simultaneously increasing contact surface area increased the ability of grasp retention and the mechanical reliability. In the location of the two removed Rhea-I fingers, two additional pieces were added to the end-effector in order to maximize its performance.

A mini-USB camera was attached on the upper part of the end-effector to allow the driver to target and confirm sample capture from a clear point of view. The camera also provides a close-up video feed of the sample in order to confirm its characteristics prior to capture. On the lower portion of the end-effector, a metallic grid was added to prevent a captured sample from falling while the robotic arm is retracting at an angle towards the basket.

It is intended to add joint angle sensors to the manipulator and control algorithms to the primary vehicle processor to allow resolved-rate Cartesian control of the end-effector end point. Also, a reverse kinematics mock-up system has been designed in order to perform the movements of the reverse kinematics system into the real sampling arm from the control station in Maryland to competition in Texas. Following this development, OpenCV will be implemented on the vehicle computer to process visual data from onboard cameras and to perform color scans and area mapping on visual images. Since the designated samples are all color coded, this will allow the wide-field navigation cameras to scan and automatically designate potential targets, and will allow the remote operator to bring the vehicle within sampling distance of a target. And with a single discrete command, autonomous sample grasping and collection can be performed.

## **2 Electronics**

The electronics onboard RHEA-II has been entirely revamped since last year's competition. The first two months of RHEA-II's reconfiguration were spent trying to test the arm while salvaging last year's wiring job. Unfortunately, the rover lacked wire management, required circuit protection, had inconsistent color coordination for the wiring, and many important components were missing. After attempting to reverse engineer RHEA-I, this year's electronics team ultimately decided to gut the rover and start the wiring from scratch. RHEA-II's electrical improvements are in the wire management, air flow to internal components, motor efficiency, and internal accessibility.

All of the internal hardware noted above has been strategically mounted so that vital elements are easily accessible. The wiring now has a consistent color code, and the connections are made in such a way that minimizes wire pulling and fatigue. In areas where high vibrations are expected, the wires have been padded to avoid loose connection concerns. Overall, RHEA-II's wiring has been simplified and now offers the team a more manageable robot to troubleshoot.

### **2.1 Power**

The entire system is powered by a LiFePO<sub>4</sub> battery capable of supplying 768 W-h at 12.8V. The wiring is done such that the power for all movable parts (arm and wheels) is controlled by an emergency stop button located on the rear of the vehicle, while the power for the computer is controlled via a separate switch. Unlike last year's design, all systems are now fuse protected using a 2012 FRC power distribution board to prevent any short-circuits. The figure below shows RHEA-II's power configuration

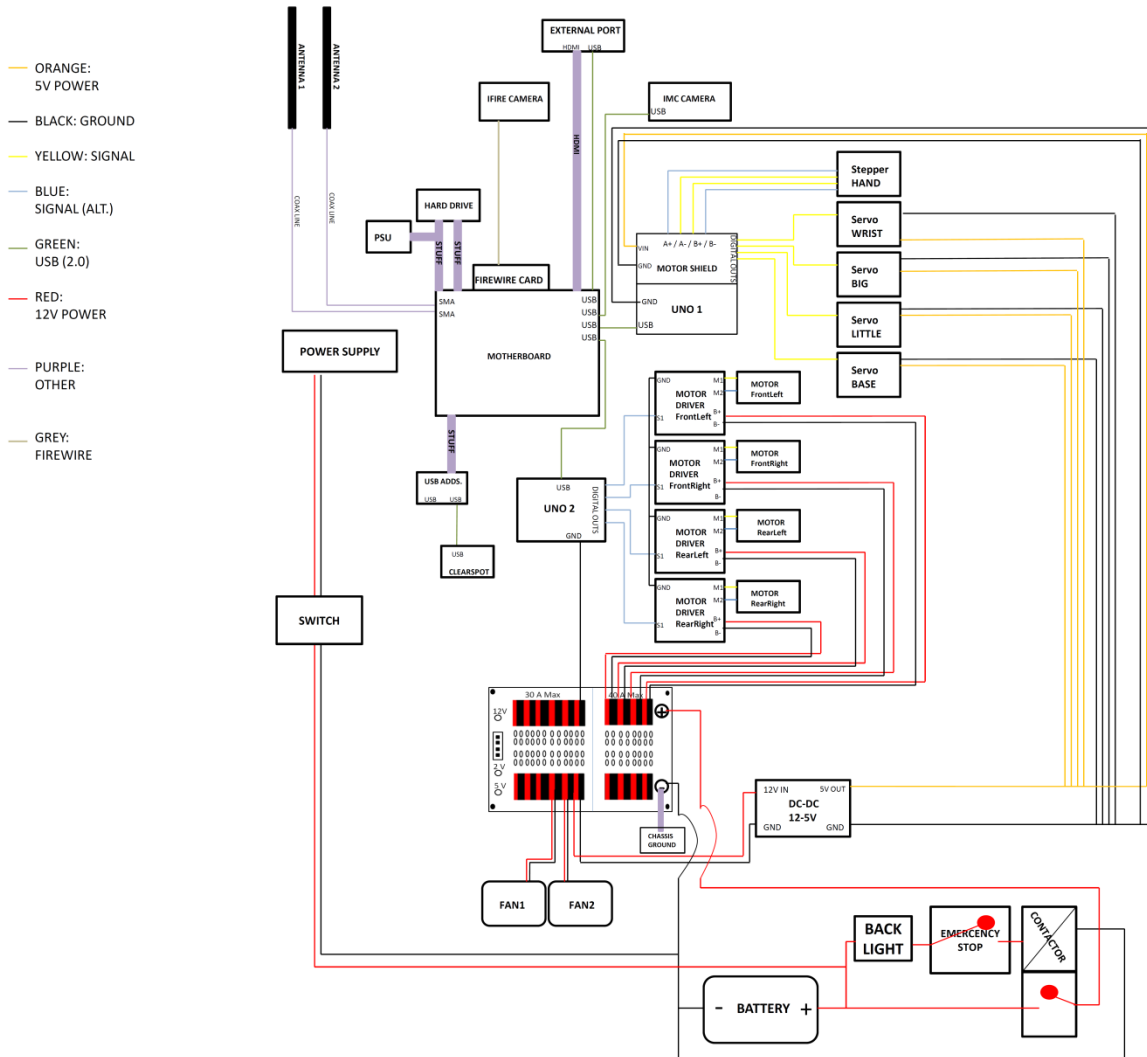

## 2.2 Controllers

Microcontrollers are used to operate the arm and wheels. An Arduino Uno with a motor shield controls four SPG785A servos and a TSFNA25 linear actuator (actually a stepper motor) which constitutes the arm and end effector. Currently, the motion is performed joint-by-joint, but a master-slave system is in development. This system would use a model arm with potentiometers in place of the servos allowing for a direct mapping of the pot. reading arrays into motion of the entire arm. Four SyRen 25 motor drivers power the AME 218-series motors for the four wheels of the RHEA-II. The signals for these drivers are managed through a second Arduino Uno. In order to monitor the amount of current being drawn by each major subcomponent, the electronics have also incorporated six new current sensors. Four sensors will monitor the wheels, one sensor will monitor the arm's motors, and the last sensor will directly monitor the battery. Finally, the heart of the machine is the computer—a ZOTAC 880GITX-A-E with a 3.1GHz quad-core processor and 4GB of RAM. The computer manages the Arduinos (USB 2.0) and all the cameras (6x USB2.0 + 1x FireWire).

## 2.3 Cameras

One of the goals for RHEA-II was to address camera issues from RHEA-I and improve the system overall. RHEA-I used four onboard cameras in total: three cameras were mounted on the mast and one camera was mounted on the front of the vehicle. The cameras were stationary and provided no zoom feature. Furthermore, RHEA-I ran into issues when trying to switch camera feeds. The control interface implementation made it difficult to change cameras and ultimately only the front-mounted driving camera was used. This made navigation of the course and location of targets difficult.

RHEA-II uses a set of three cameras: a front-mounted firewire webcam as a driving camera, a pan-tilt-zoom (PTZ) camera as a surveying camera, and a mini-webcam mounted on the end effector to give a "first-person" view from the arm. The most profound of the upgrades is the use of a PTZ IP Camera. The Panasonic BB-HCM581A is attached atop a deployable mast to be used for surveying. The PTZ surveying Camera will be used simultaneously with the firewire webcam to steer RHEA-II to a desired location. When at this location and performing retrieval of an object, the PTZ surveying camera will be locating the next target. This camera has a frame rate of 30 frames/sec, a pan angle of  $-175^{\circ}$  up to  $+175^{\circ}$ , and a tilt angle of  $-120^{\circ}$  to  $0^{\circ}$ . Additionally it provides 21x optical zoom. When in testing, this zoom magnified objects 200 ft away to where details can be seen. The PTZ features will allow RHEA-II to locate target objects from afar with precision.

The firewire webcam (shown below) used was the Unibrain fire-i digital camera which was the same as on RHEA-I, and will be mounted below the chassis in front of the rock basket. This camera's main purpose is to provide views of the blind spot that the surveying camera atop the mast cannot see. The Unibrain camera has been tested in bright sunlight, which demonstrated its ability to visually differentiate obstacles while undergoing a steady dynamic response.



The mini Hootoo Y113 USB webcam is attached to the end effector to give the team a direct view of where the target object is in relation to the grappling mechanism. The mini webcam has been tested to differentiate different colored objects at close range while undergoing a minimum dynamic response. The picture below shows the configuration of the webcam on the end effector.

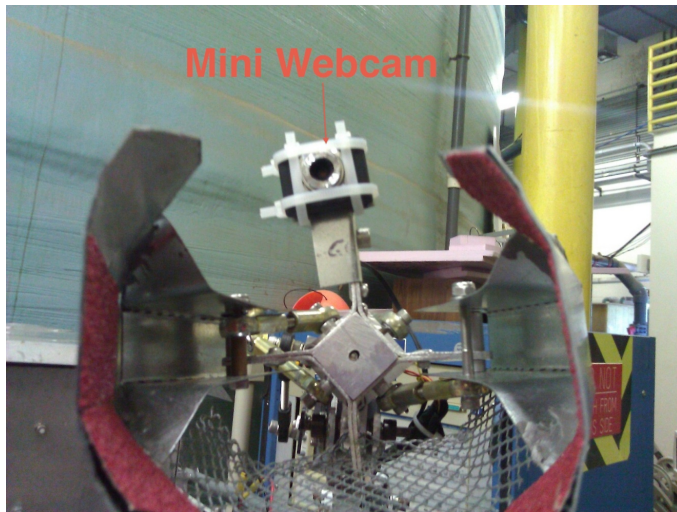

## 2.4 Communications

Communications are accomplished with a Sierra Wireless 802.11n router on the Clearspot 4G network, which is hooked via USB to the vehicle computer. Data sent across this link includes the video feed from any one of the multiple cameras, sensor data, and controller input from the crew station. The various data will be transmitted via multiple concurrently running sockets. This system has very good 4G reception in the JSC Rockyard area, and also works for testing on the University of Maryland campus.

## 2.5 Software

One of the goals established at the beginning of the project was improved control of the sampling arm, relieving the operator from the need to perform joint-by-joint control of manipulator motions. Inverse kinematics, a means of translating desired Cartesian coordinates to servo angle rotations, were the desired solution. A solution was derived, but with much error. An additional attempt was made recently using the software OpenRAVE for testing and kinematic solving. Unfortunately, due to time constraints, a stable solution has not been found. Much of the difficulty surrounded familiarity with the software, but with proper knowledge of its use a solution is feasible for the next competition. Another alternative considered but abandoned due to manufacturing time was a master/slave model of arm control where a replica of the arm would have encoders at each joint to read the rotation values and feed them to the arm on the rover. For the sake of reliability, the individual control of the servos for moving the end effector to the desired position will be used. To reduce the time to move the end effector properly, a series of joint rotations have been devised to get desired basic planar movements. An improvement which has been implemented is the automated sample collection after the end effector takes hold of a sample. The arm will now pick up the rock and put it in the sample collection area without further operator input.

The system architecture aboard RHEA-II has drastically changed from a complex group of services to a simple script which controls the main processes of feeding video, receiving and executing crew station arm and wheel movements, and executing operating system commands remotely. A system diagram is shown below.

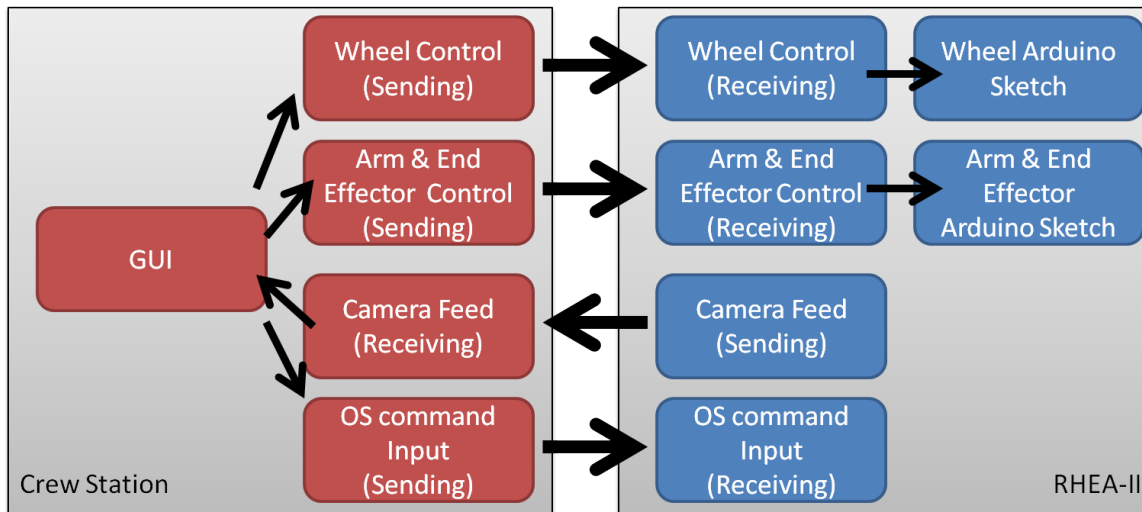

One of the most significant shortcomings of the RHEA-I architecture for 2011 was the software used in the remote control station. This was left to the last minute and some functionality (such as the camera switching on command) was not implemented reliably. Now, camera switching happens seamlessly. Regarding the desired improvements in video feed, the actual throughput of the link left much to be desired in terms of observing multiple feeds. Further investigation into compression methods to make this a reality will be continued into the next competition. Single video feeds with switching capability work reliably at the moment, and will be used for the competition. In addition, a significant change in the crew station GUI has been implemented. The new crew station setup will include the video feed, camera switching capability, the same joystick configuration, and inputs to change the rotation of the individual servos on the arm and end effector. The underlying software architecture is very similar to the rover's regarding simplicity, but instead of receiving and executing, the inputs are received and sent.

## 2.6 Video Streaming

A requirement for the RoboOps competition is that the team must post a live stream of the video taken during the competition. This will be accomplished by hosting through [www.ustream.tv](http://www.ustream.tv). The hosting available from this site allows the stream to be embedded as required by the rules. The channel is <http://www.ustream.tv/channel/rhea2>, and the embed code was reported to the competition committee as part of the midpoint review. Although it is required that the team must stream the video, there are two ways we are considering doing it. Both options will work but it has not been determined which will be used. Option 1 is to simply host a screenshot of the screen that the controller will be using during the competition. This option would allow viewers to get a perspective of how it is controlled in addition to what the vehicle is seeing, but it will also make the image more difficult to view and may confuse the viewer. The second option is the more standard option of simply routing the video stream from RHEA-II to ustream as well as the GUI. Although every attempt would be made to live stream the video, the stream sent to the GUI would be a priority in the event that managing both feeds at once becomes impossible. This is unlikely however, and this stream would provide the viewer with a full screen view of what the rover is looking at.



### 3 Testing

The Tumbler was a part kit that was acquired in the attempt to test out both small software changes and practical driver training when Rhea-II was non-operational. The Tumbler, in the figure shown below, is a six wheel vehicle that takes advantage of skid steer principles where the three wheels on one side all travel in the same direction at the same rate. This is then combined with the wheels on the other side to perform actions such as travelling forward, backwards, and sideways. The significance of the Tumbler to have is so that it could have very similar code to that of RHEA so any tweaks and changes could be implemented a similar test bed before possibly harming our working project. Other tests that the Tumbler was vital for were the camera mount, camera software, and camera visual information tests. Instead of creating unnecessary holes in the frame of RHEA, cameras were mounted on the Tumbler, which was designed to have top plate similar to that of an optic table setup. This allowed for ease of mounting in different sizes and places. The major advantage was really the ability to test out the resolution of the cameras outside and inside in a relatively fast manner compared to the amount of time that it would have taken to put it on RHEA.



The Tumbler was very advantageous in the sense of training multiple pilots early and at the same time. Acquisition of the Tumbler was done almost at the onset of the program so that training could begin two weeks in. This training has gone through a number of variations and upgrades. Training with the new equipment has evolved as new equipment was acquired, from RHEA-I's small webcams to RHEA-II's final PTZ surveying camera. To prepare for the RoboOps competition, the priority since RHEA-II became operational has been to ensure that the drivers can practice as frequently as needed. Since the start of RHEA-II, at least two drivers have been constantly practicing with either the Tumbler or RHEA to get familiar with the system.

## 4 Education and Public Outreach for RHEA II (Ros\_E)

Education and Public Outreach (E/PO) is one of the main requirements put forth by RASC-AL in the rover design competition. It is a fundamental goal of scientific research to try and promote growth and learning in the areas of Science, Technology, Engineering, and Mathematics which form the acronym STEMS. Each student on the Rover Design Team has a solid base in STEMS subjects, so it was decided that a large effort would be put forth in the group to promote awareness of these subjects. The focus of the outreach was not just a specific educational environment, but the general public in all age groups. It was with this idea in mind that the University of Maryland Rover Design Team pursued three different areas where open minds could be reached. These three focus areas were K-12, the university level, and the general public. These focus areas were reached through a Facebook page, Twitter account, Youtube profile, a blog, and outreach events. The outreach events were:

### 4.1 K-12: Parkland Magnet Middle School for Aerospace Technology

Background: Parkland Middle School is a school located in Rockville, Maryland that specializes in mathematics and science focused on the problem-solving requirements of aerospace and robotic engineering. The fact that it is a school that focuses on Aerospace technology and robotics means it is a perfect fit for the public outreach of the Rover Design Competition promoted by NASA. The education and public outreach at this school helps reinforce the idea that the students education builds up to something bigger. *“At Parkland, we believe that every student regardless of socio-economic status, ethnicity, past history, and academic background should have access to opportunities for success socially and academically in our unique whole school magnet program. We have an obligation to provide the support necessary for every student to succeed.”* This was the mission statement of the school and it resonates with the idea that the Maryland Design Team believes in, that each person should have an equal opportunity to pursue what they want to (in this case being planetary rovers) and so the University of Maryland students contacted the school in an effort to present on Ros\_E.

Presentation: The UMD Rover Design Team members were invited to speak with two classes. One was a 7<sup>th</sup> grade class for robotic engineering and the other was an 8<sup>th</sup> grade class for Introduction to Engineering. It was in these two classes that the Rover Team presented on RHEA II nicknamed Ros\_E (in an effort to make it memorable). The presentation included three full poster boards on the internal components of Ros\_E as well as a PowerPoint on the competition taking place in Houston. Students were encouraged to ask questions and after the students of Parkland were allowed to present the projects they were working on as well. These included programmable walkers with Lego NXTs as well as wooden limbs powered by hydraulics.

Social Impact: The students seemed eager to hear more about the Rover and competition after the presentations were done. In the feedback section, many wrote down that they wished to follow a career into Aerospace engineering and wanted to work with robotics. Overall the presentation showed the students how their knowledge has the possibility of culminating into something as advanced as a planetary rover.

## 4.2 Public: Rockville Science Day



Background: Rockville science day was on April 15<sup>th</sup> at Montgomery College and was sponsored by the city of Rockville. The focus of the day is to emphasize how science is basic to society. The necessity to focus on science and technology in order to solve fundamental societal problems is stressed. Rockville science day invites individuals and organizations from the surrounding area to bring a hands-on exhibit to display. Over 60 exhibitors, including the University of Maryland Robo-ops team were present. The audience at Rockville Science Day was a broad spectrum ranging from young children to adults.

Presentation: The University of Maryland Robo-ops team sent five students so Rockville Science Day. The presentation consisted of three posters designed to reach out to all audiences. A child friendly poster with pictures of famous robots such as Wall-E, talked generally about rovers and space exploration. An intermediate poster was created to target middle and high school students. This poster focused more on our rover, RHEA-II, and talked specifically about what features were important. The third poster was the most technical of the three and was used to address interest from professional engineers or college students. In addition to the posters, the Tumbler, used for testing the code of RHEA-II, was brought in order to give the audience something to interact with and drive.

Social Impact: The main influence of Rockville Science Day most likely will come in the excitement generated for robotics and the University of Maryland. Many children, from K-12, were excited by the opportunity to drive Tumbler. For many of them, this was probably the first experience they have had using a technology developed at the university level hands on. The ability to drive the Tumbler from a laptop and onboard camera is something that is not typically commercially available, and served as good basic example as something the kids could do if they pursue robotics. In addition to the many questions we fielded from kids about how they could get involved in building something like this, the parents had their own inquiries. A few parents were interested in the technical details of the rover, but a majority was interested in the program we were in. They saw the program as a great opportunity for their children and seemed encouraged with how simple in can be to be involved. The result of Rockville Science Day was definitely the inspiration of some parents and kids to look into becoming involved with robotics and space exploration.

### 4.3 Public: Maryland Day



Background: Every year the University of Maryland has a campus-wide event where clubs, labs, and departments set up stands to present. The event is open to the public and this year over 65,000 thousand visitors attended. These visitors are people of all ages and backgrounds but are typically families. The Robo-ops sent 10 people to Maryland Day, but the atmosphere is not one where a long in depth presentation can be made. Most interactions simply touch on the cursory details of the competition and the rover. There are however, opportunities for more personal in depth interactions.

Presentation: The posters created for the other presentations, including Rockville Science Day, were displayed at Maryland Day. These posters allowed the students to interact and relate to every visitor from young child to professional engineer. Most of the interest in the posters on Maryland Day came from professionals from the region and past University of Maryland graduates. Many people were intrigued by the competition and the specifics of our testing and competition strategy. Some individuals even suggested improvements and strategies, and although none of these suggestions were practical/desirable to do, simply having an open dialogue helped garner interest in the project.

In addition to the posters we had RHEA-II on display, but disconnected. Although we were not willing to risk letting anyone drive it, it did attract attention from many visitors. One of the main points of interest was what all of the electronic parts were, and specifically how much they cost. For people who wanted to interact with a rover, the Tumbler was also present at Maryland Day. We explained to people that it was simply being used to test the code, but they were impressed by the speed and maneuverability.

Social Impact: The impact of Maryland Day was will probably be a residual, lingering effect. The Robo-ops team was not specifically advertising any program, but simply research into robotics and space exploration. The association with the University of Maryland more than likely will inspire some people who were passionate about our project, to attend Maryland and work on similar projects. Although these people will not necessarily be driven to work on the same project, by displaying what joining a STEM major opens up to you, we have influenced the path they will take. Maryland Day was truly a day where the Robo-ops team had a chance to focus purely on STEM promotion, and display what working in the field can produce.

#### **4.4 University: Undergraduate Research Day**

Background: Undergraduate Research Day is an event held at the University of Maryland. The purpose of the event is to highlight research performed by undergraduates, which oftentimes can be overlooked on the university scale. The research day includes research by students of all different majors. The research ranged from historical theory to modern scientific concepts. A requirement for the day was to produce a poster, so we provided the three posters we had previously used, and a fourth outlining all of the progress we had made.

Presentation: Although we had posters for any audience, most of the visitors were professionals from the surrounding area and other students. RHEA-II was brought to the presentation which made us stand out from most of the other researchers who simply brought posters. Because of the rover being present many people were curious as to what we were doing with a rover. Many people were intrigued by the competition and how we planned on winning. Overall there was a lot of support for our cause and appreciation for the scientific basis of our research, in contrast to many of the other presenters. Thanks to RHEA-II being present, the Robo-ops team was asked for an interview about the competition and project. This video highlighted the undergraduate research days top projects and sponsors.

Social Impact: Although Undergraduate Research Day was a great opportunity to meet new people and tell them about our project, few of those people were young or still had the ability to switch fields to STEM. The largest social impact from the day likely came from the video of the interview which was posted online. Hopefully it will be seen by other students at the University of Maryland, or prospective students. Through being highlighted as one of the premiere research projects at Maryland, future students may decide to join the Robo-ops team or work on other STEM projects.

#### **4.5 University: University of Maryland, College Park Scholars**

Background: The University of Maryland Scholars program provides intellectual challenges and collegial support for engaged and academically talented freshmen and sophomores. Specifically, the one that the rover design team reached out to was the Science, Technology, and Society (STS) sector which looks at the relationship between these subjects and society. This specific program correlates well with STEMS as most science and technology fields also correspond to engineering and mathematics as well. The education and public outreach to these students was deemed important because in this case the rover design team was targeting freshmen and sophomores of the University, many of whom are pursuing a major in Computer Science, Engineering, or Mathematics.

Presentation: The UMD Rover Design Team presented on the merits of sticking with their respected STEMS related major and used this to move into the competition of designing a planetary rover. Students were given a presentation by several of the seniors in Aerospace engineering and the experiences they had in college. The scholar's students were given an opportunity to ask questions about both: college life as an Engineer as well as Ros\_E the Rover.

Social Impact: Overall, the STS students were shared experiences of students who worked hard through college to get to where they were. The UMD Rover Design students explained how after the first two years students will tend to have more freedom with their schedule and are able to pursue their own interests. Robotics and engineering are high on the list of interests for Aerospace engineers so the Rover Design technical elective can be a good choice for those interested in similar things. What was not known before the presentation to the STS students was the fact that several technical electives can be taken by ANY major and this was an eye opening experience as students who were computer science or math majors could still pursue their interests in robotics, among others.

#### 4.6 Surveys for K-12 and University EPO Events

At the finale of our presentations at the K-12 and University E/PO events, we asked the audience to complete a short survey about the presentation. The questions we asked included:

- What field or major do plan to study?
- Are there any other topics of the competition you would like to learn more about?
- Would you like to compete in the Robo-Ops competition or a similar event?

We also asked the audiences to rate our presentation to ensure that we were covering relevant material in an engaging manner. On a scale of 1 to 5 with 1 being poor and 5 being excellent, we averaged a 4.1 so we felt we were adequately reaching our audience.

We received a total of 28 responses at the K-12 level and 33 responses from the University group. The results for all three questions varied but some interesting trends were found. In terms of additional topics wishing to be covered, the majority from both academic groups were interested in learning more about the design and structure of the rover – both mechanical and software related. Many students were also interested in learning more about the rules of the competition and several asked how confident we were that we would perform well at the competition.

The results of the other two questions can be seen in the table below. An interesting trend is the greater interest in the Robo-Ops competition at the K-12 level in spite of the greater proportion of students wishing to study engineering at the University level.

##### Would you like to compete in the Robo-Ops competition or a similar event?

Field	K-12				University					
	Yes	Maybe	No	Tot.	Yes	Maybe	No	Tot.		
Engineering	14	1	-	15	54%	14	4	2	20	61%
Comp. Sci.	1	-	-	1	4%	1	2	1	4	12%
Natural Sciences	-	-	-	-	-	2	-	-	2	6%
Medicine	3	4	-	7	25%	-	-	4	4	12%
Business	-	-	-	-	-	-	1	2	3	9%
Legal	-	-	1	1	4%	-	-	-	-	-
Other	2	-	2	4	14%	-	-	-	-	-
<b>Total</b>	<b>20</b>	<b>5</b>	<b>3</b>	<b>28</b>		<b>17</b>	<b>7</b>	<b>9</b>	<b>33</b>	
	71%	18%	11%			52%	21%	27%		